

Apollo XL grading machines

Apollo XL is specifically designed for the safe grading of portion-size fish and post smolt. The machine features the same high quality, industry proved Apollo grader that customers worldwide have come to trust since 1982.

The XL machine is available with 4 or 5 tracks – all with various options when it comes to roller distance, number of outlets and type of dewaterer. Recommended max fish size is ca. 1.5 kg.



Flushing water and a well proven design ensures a gentle grading process



Dewaterer designed to grader model, fish size and water flow

Model	4-track XL	5-track XL
Roller length, cm	200	200
Roller diameter, mm	89	89
Roller distance, mm	2-45 / 12-55 / 22-65	2-45 / 12-55 / 22-65
Number of outlets	2, 3 or 4	2, 3 or 4
Outlet size, mm	200	200
Motor, kW	0.25	0.25
Weight, kg *	400	475
Dimensions, cm **	330x104x130	330x127x132

* Weight is without dewaterer, and will also be depended upon number of outlets
 ** Length is without dewaterer, exact width will be depended upon roller distance

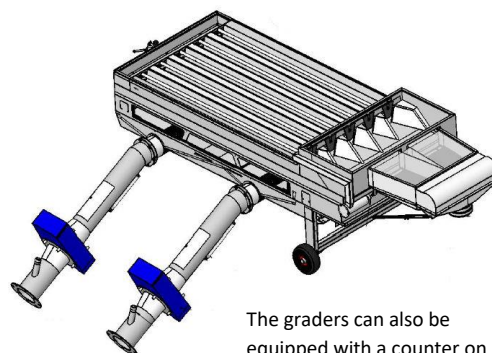

The graders can also be equipped with a counter on each outlet.